

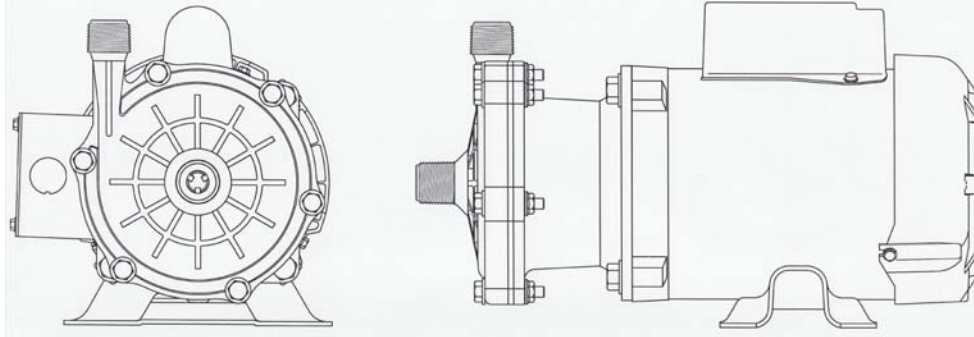

MARCH PUMPS

1819 PICKWICK AVE., GLENVIEW, IL 60026-1306, U.S.A
 PHONE: (847) 729-5300 - FAX: (847) 729-7062
 WWW.MARCHPUMP.COM

INSTRUCTIONS & REPAIR PARTS FOR SERIES 335 PUMPS



PUMP OPERATION

March 335 Series pumps feature a magnetic coupling that eliminates the seals found in conventional pumps. This means that there is no place in the pump where leaks can occur.

Coupled with this design is an impeller bearing that is lubricated by the pump fluid. Consequently, adequate bearing lubrication is critical. Therefore, the pump should never be run dry. Similarly, the pump should not be run against a closed discharge valve, as this prevents liquid circulation and causes a temperature rise inside the pump, which could lead to pump damage.

The 335 Series models are not self-priming. The pump must have a positive source of liquid connected to its inlet port. The pump should be positioned such that it is below the liquid level of the source tank and the piping leading to the pump never rises higher than the centerline of the pump.

RATINGS AND SPECIFICATIONS

| MODEL NO. | CONNECTORS | | ELECTRICAL | | | | | | | MAX FLOW | MAX HEAD | MAX TEMP. | MAX INT. PRESSURE | PACK WEIGHT |
|-----------|----------------|----------------|------------|-------|---------|----|-------|---------|------|----------|----------|-----------|-------------------|-------------|
| | INLET | OUTLET | HP | PHASE | VOLTS | Hz | WATTS | AMPS | RPM | | | | | |
| 335-AP-MD | 3/4" OD Smooth | 3/4" OD Smooth | 1/3 | 1 | 115/230 | 60 | 400 | 3.6/1.8 | 3450 | 12 GPM | 68 FT. | 190°F | 50 PSI | 21 Lbs. |
| 335-CP-MD | 3/4" MPT | 3/4" MPT | 1/3 | 3 | 230/460 | 60 | 455 | 1.3/0.6 | 3450 | 12 GPM | 68 FT. | 190°F | 50 PSI | 21 Lbs. |

| MODEL NO. | CONNECTORS | | ELECTRICAL | | | | | | | MAX FLOW | MAX HEAD | MAX TEMP. | MAX INT. PRESSURE | PACK WEIGHT |
|-----------|----------------|----------------|------------|-------|---------|----|-------|---------|------|----------|----------|-----------|-------------------|-------------|
| | INLET | OUTLET | HP | PHASE | VOLTS | Hz | WATTS | AMPS | RPM | | | | | |
| 335-AP-MD | 3/4" OD Smooth | 3/4" OD Smooth | 1/3 | 1 | 115/230 | 50 | 303 | 4.4/2.2 | 2850 | 10 GPM | 48 FT. | 190°F | 50 PSI | 21 Lbs. |
| 335-CP-MD | 3/4" MPT | 3/4" MPT | 1/3 | 3 | 190/380 | 50 | 336 | 1.0/0.5 | 2850 | 10 GPM | 48 FT. | 190°F | 50 PSI | 21 Lbs. |

PUMP SERVICING

The pump is disassembled by removing the six 1/4-20 screws & nuts and 1/4" washers that hold the front and rear housings together. Now the front housing can be removed, followed by the impeller.

Inspect the impeller at its front and rear faces as shown in Figs. 1 & 2. Look for scoring or excessive wear. If either of these is present, the impeller should be replaced. Also measure the inside diameter of the impeller on both ends where the shaft passes through it. The original dimension is 0.254/0.256. If this dimension measures greater than 0.260, the impeller should be replaced. Refer to the repair parts list for replacement part numbers.

Figure 1. Impeller front face.

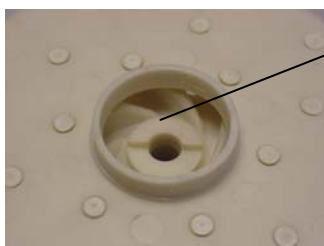
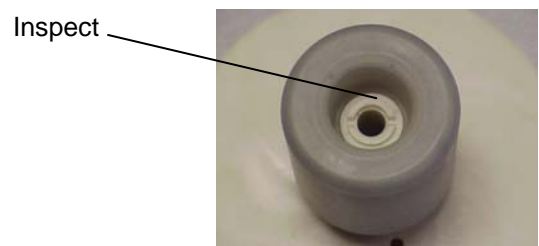
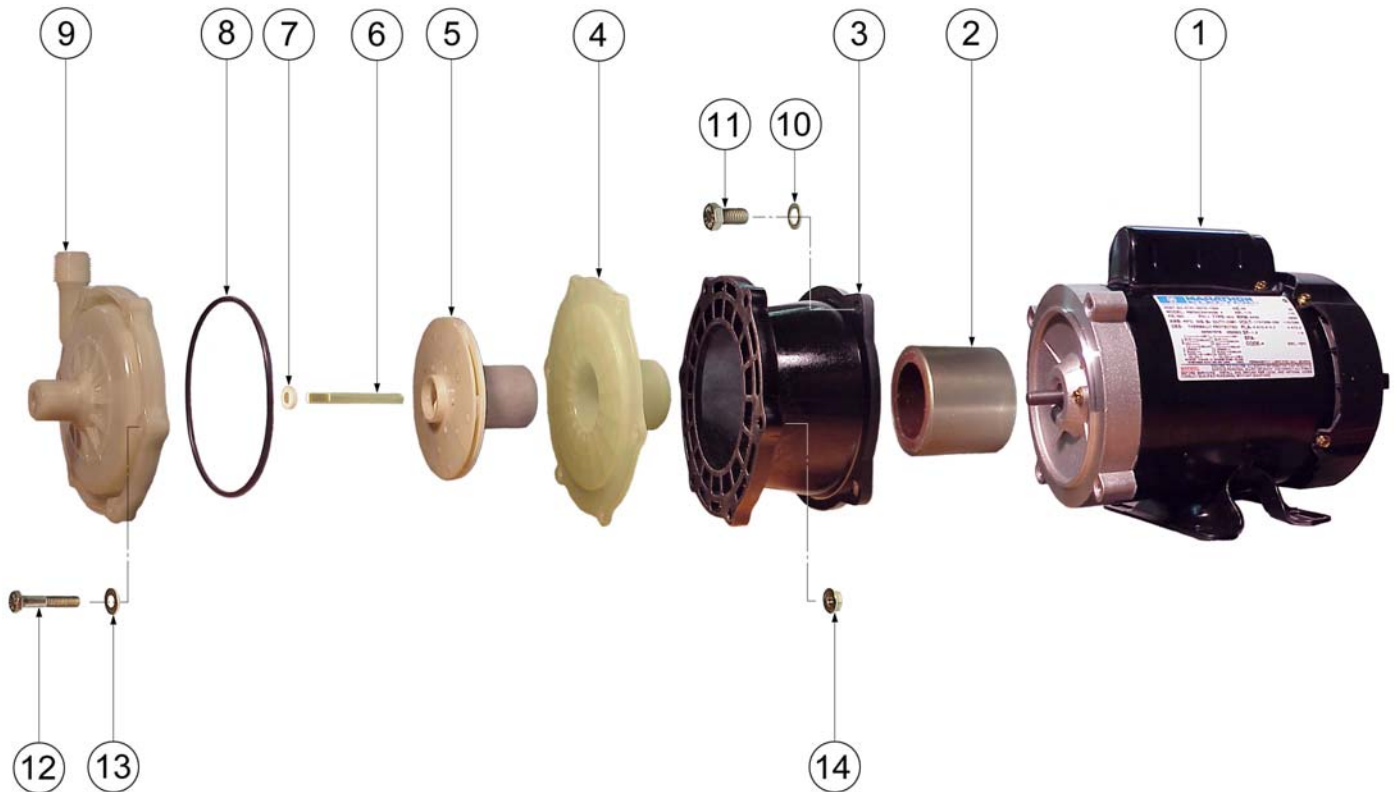

Figure 2. Impeller rear face.





| SERIES 335 REPAIR PARTS | | | |
|-------------------------|--|------|----------------|
| ITEM | DESCRIPTION | QTY. | PART NO. |
| 1 | Motor (TEFC) 1 Ph, 1/3 HP | 1 | 0151-0015-1000 |
| * | Motor (TEFC) 3 Ph, 1/3 HP | | 0151-0039-1000 |
| * | Motor (XP) 1 Ph, 1/3 HP | | 0151-0023-1000 |
| * | Motor (XP) 3 Ph, 1/3 HP | | 0151-0042-1000 |
| 2 | Drive Magnet Assembly | 1 | 0151-0061-0200 |
| 3 | Motor Bracket | 1 | 0335-0010-1000 |
| 4 | Rear Housing (Polypropylene) | 1 | 0335-0004-0100 |
| 5 | Impeller (Polypropylene) | 1 | 0335-0005-0200 |
| * | Impeller w/carbon bushing | | 0335-0005-0400 |
| * | Impeller w/mica Teflon bushing | | 0335-0005-0500 |
| 6 | Shaft (Ceramic) | 1 | 0130-0024-1000 |
| 7 | Thrust Washer (Ceramic) | 1 | 0821-0079-1000 |
| 8 | "O" Ring (Viton) | 1 | 0335-0009-1000 |
| 9 | Front Housing – Threaded (Polypropylene) | 1 | 0335-0002-1000 |
| * | Front Housing – Smooth (Polypropylene) | | 0335-0003-1000 |
| 10 | Washer (Stainless) | 4 | 0155-0019-1000 |
| 11 | Screw (Stainless) | 4 | 0155-0017-1000 |
| 12 | Screw (Stainless) | 6 | 0153-0011-1000 |
| 13 | Washer (Stainless) | 6 | 0157-0023-1000 |
| 14 | Lock nut (Stainless) | 6 | 0156-0053-1000 |

* Optional configuration (not shown)

Contact factory for other materials and/or parts not listed.

LIMITED WARRANTY

March pumps are guaranteed only against defects in workmanship or materials for a period of one year from date of manufacture pumping water. On all other solutions, contact the factory for application assistance. March Pump Application Worksheet 750-130-10 is available for additional warranty information.