

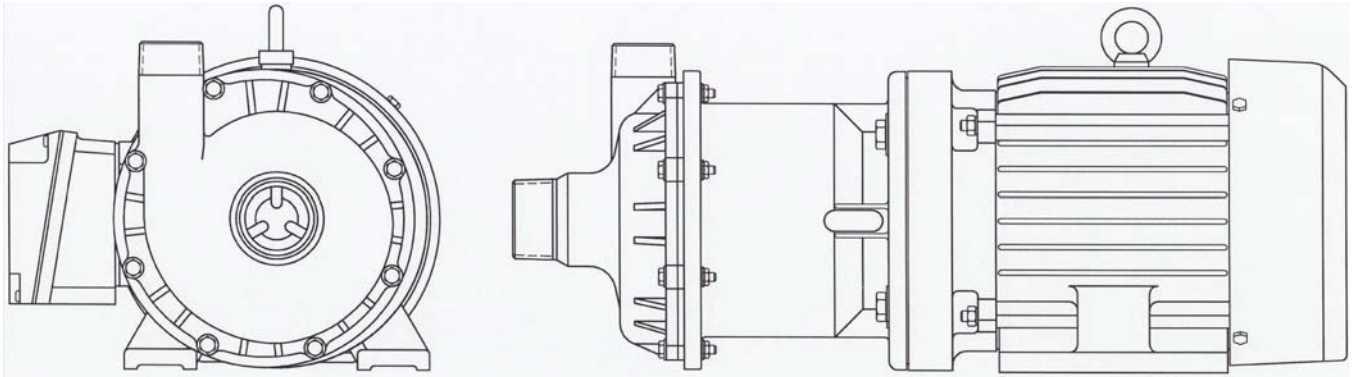

MARCH PUMPS

1819 PICKWICK AVE., GLENVIEW, IL 60026-1306, U.S.A
 PHONE: (847) 729-5300 - FAX: (847) 729-7062
 WWW.MARCHPUMP.COM

INSTRUCTIONS & REPAIR PARTS FOR MODEL TE-8K-MD AND TE-8C-MD



MODEL TE-8C-MD
 ASS'Y P/N 0157-0008-0100

MODEL TE-8K-MD
 ASS'Y P/N 0157-0008-0200

RATINGS AND SPECIFICATIONS

MODEL NO.	CONNECTORS		ELECTRICAL			GPM AT LISTED HEAD						PSI GAGE	DIMENSIONS			PACK WT.
	INLET	OUTLET	HP	VOLTS	AMPS	1 FT.	10 FT.	30 FT.	50 FT.	70 FT.	90 FT.		HT.	WD.	LG.	
TE-8C/K-MD	2" MPT	1½" MPT	3	230/460	7.8/3.9	135	130	116	95	72	35	41.0	9¼	13 1/16	25¼	151 lbs.

PUMP CONSTRUCTION & SERVICING

March "Orbital" Magnetic Drive Pumps eliminate the conventional shaft seals found in most pumps. This means that there is no rotating shaft or seal to wear and allow the liquid being pumped to leak out. The only seal in the pump is a stationary Viton "O" ring seal between the front and the rear Housings.

The pump can be serviced with the use of an adjustable wrench. The only moving part in the pump, other than the motor, is the Impeller-Magnet Assembly, which rotates on a stationary ceramic spindle and up against a ceramic thrust washer. These are the only parts that might wear, and require replacement. See the Repair Parts List for replacement parts.

Do not over tighten the 8 Housing Screws (item 13) or you may crush the plastic Housing bosses. Tighten all screws uniformly.

ELECTRICAL & OPERATION

The standard pump has a TEFC severe duty motor, 230/460 volts, 60 cycle, 3 phase, 3450 r.p.m. rated as continuous duty. A junction box is located on the side of the motor for making the electrical hook up.

The wiring instructions are located on the motor label or on the junction box cover. The motor has U.L. yellow card recognition.

Pumps are not self priming and will not produce a suction lift and must be installed with a positive flooded suction. We rely on the liquid being pumped to lubricate the Impeller-Magnet assembly bushing spinning on the stationary ceramic spindle. If the pump is run dry for longer than 60 seconds, the Impeller bushing may "freeze" onto the spindle. The direction of motor rotation should be clockwise looking into the inlet of the pump.

PUMP MATERIALS

All plastic parts of the pump are molded out of talc filled polypropylene or Kynar. The stationary spindle and Thrust Washers are made of porcelain ceramic. The "O" ring for the housing is Viton rubber. The bushing in the Impeller Assembly is a filled Teflon and Ryton material. There are no other materials in contact with the solution. Contact the factory for other materials that are available, or if you are uncertain of the material compatibility with your specific solution.

NOTE: When replacing impeller bushings in the field, the plastic bushings must be bored to size after they have been pressed into the impeller. Bore to .630/.632 I.D. The carbon and ceramic bushings are to finished size and do not require boring.

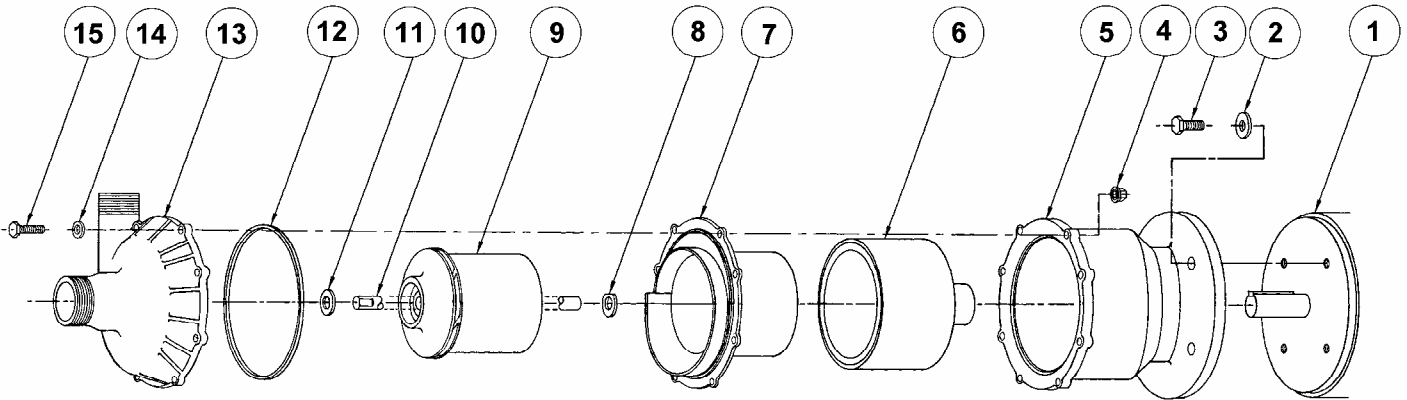

MODEL TE-8C/K-MD REPAIR PARTS LIST			
ITEM	DESCRIPTION	QTY.	PART NO.
15	1/4-20 x 1 1/2" Long Hex Hd Mach. Screw	8	0153-0011-1000
14	.281 I.D. x 5/8 O.D. x 1/16 Thk Flat Washer	8	0157-0023-1000
13A	Pump Housing (Polypropylene)	1	0157-0007-1000
13B	Pump Housing (Kynar)	1	0157-0052-1000
12	7 1/4 I.D. x 1/8 Thk, "O" Ring (Viton A)	1	0157-0011-1000
11	Thrust Washer Front (Ceramic)	1	0157-0001-1000
10	Impeller Shaft (Ceramic)	1	0157-0002-1000
9A	Impeller Final Assembly w/ Ryton Bushing (Polypropylene)	1	0157-0004-0200
9B	Impeller Final Assembly w/ Carbon Bushing (Kynar)	1	0157-0050-0500
8	Thrust Washer Rear (Ceramic)	1	0157-0009-1000
7	Magnet Dividing Housing (Kynar)	1	0157-0053-1000
6	Drive Magnet Assembly	1	0157-0005-0100
5	Motor Connecting Bracket	1	0157-0100-1000
4	Serrated Nut	8	0156-0053-1000
3	1/2-13 x 1" Long Hex Hd Cap Screw	4	0160-0031-1000
2	Washer	4	0160-0032-1000
1	Motor TEFC	1	0157-0012-1000
1	Motor Explosion Proof	1	0157-0042-1000

Contact factory for other materials and/or parts not listed.

LIMITED WARRANTY

March pumps are guaranteed only against defects in workmanship or materials for a period of one year from date of manufacture pumping water. On all other solutions, contact the factory for application assistance. March Pump Application Worksheet 750-130-10 is available for additional warranty information.



1819 PICKWICK AVE., GLENVIEW, IL 60026-1306, U.S.A
 PHONE: (847) 729-5300 · FAX: (847) 729-7062 · www.marchpump.com

0157-0021-1000 R7